

NPN

New Product News



SPADERUSH

Line Expanded With New 8D Holders

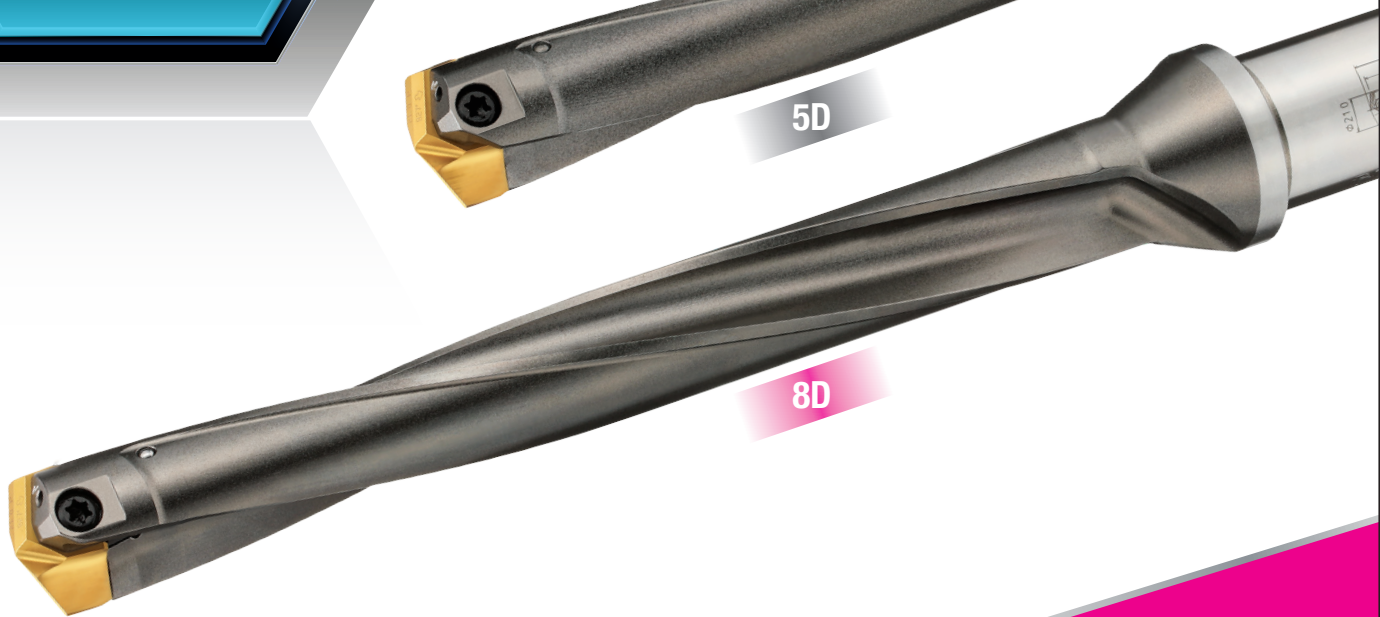
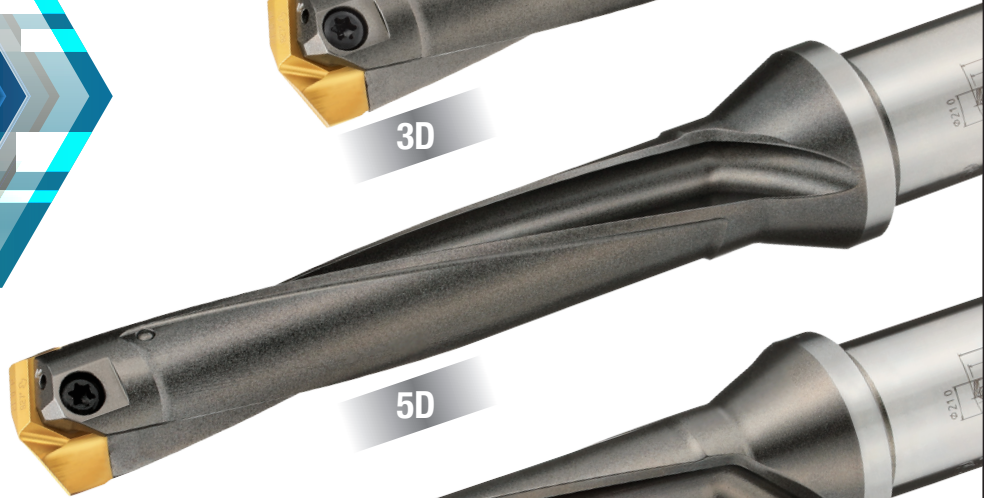

KEY POINT

TaeguTec is expanding the SPADE-RUSH line to 8D holders.

The **SPADE-RUSH** line now includes 8D holders, along with the existing 3D and 5D holders, for deeper hole machining.

The 8D holders come in a 20-41 mm diameter range.

For further technical questions, please contact the product manager.

LCD...T2-8D



Head changeable drill holder – Weldon type shank



- Drilling depth: 8x diameter

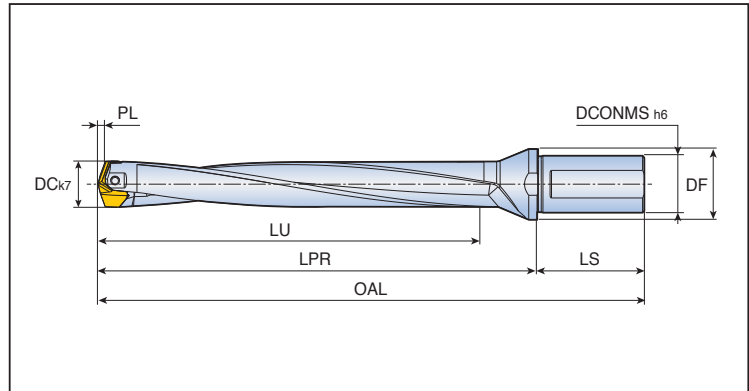

Designation	Dimension (mm)								
	DC	DCONMS	DF	LU	LPR	LS	OAL	PL	SSC
LCD 200-209-25T2-8D	20.0-20.9	25	32	163.1	192.1	56	248.1	3.11	20
210-219-25T2-8D	21.0-21.9	25	32	171.3	200.1	56	256.1	3.29	21
220-229-25T2-8D	22.0-22.9	25	32	179.4	208.4	56	264.4	3.42	22
230-239-25T2-8D	23.0-23.9	25	32	187.6	216.4	56	272.4	3.60	23
240-249-32T2-8D	24.0-24.9	32	40	195.7	230.7	60	290.7	3.73	24
250-259-32T2-8D	25.0-25.9	32	40	203.9	238.7	60	298.7	3.91	25
260-269-32T2-8D	26.0-26.9	32	40	212.0	247.0	60	307.0	4.04	26
270-279-32T2-8D	27.0-27.9	32	40	220.2	255.0	60	315.0	4.22	27
280-289-32T2-8D	28.0-28.9	32	40	228.4	268.4	60	328.4	4.35	28
290-299-32T2-8D	29.0-29.9	32	40	236.5	276.4	60	336.4	4.53	29
300-309-32T2-8D	30.0-30.9	32	42	244.7	284.7	60	344.7	4.67	30
310-319-32T2-8D	31.0-31.9	32	42	252.9	292.7	60	352.7	4.85	31
320-329-40T2-8D	32.0-32.9	40	48	261.0	303.0	68	371.0	4.98	32
330-339-40T2-8D	33.0-33.9	40	48	269.2	311.0	68	379.0	5.16	33
340-349-40T2-8D	34.0-34.9	40	48	277.3	319.0	68	387.0	5.34	34
350-359-40T2-8D	35.0-35.9	40	48	285.4	327.4	68	395.4	5.44	35
360-369-40T2-8D	36.0-36.9	40	48	293.6	335.4	68	403.4	5.62	36
370-379-40T2-8D	37.0-37.9	40	48	301.8	343.4	68	411.4	5.80	37
380-389-40T2-8D	38.0-38.9	40	50	309.9	356.9	68	424.9	5.91	38
390-399-40T2-8D	39.0-39.9	40	50	318.1	364.9	68	432.9	6.09	39
400-410-40T2-8D	40.0-41.0	40	50	326.3	372.9	68	440.9	6.27	40

- SSC: Seat size code
- It is recommended to make the pilot hole with a 3D holder

Spare parts

Designation	Screw	Wrench	Wrench handle	
LCD 200-219-8D	TS 40178D25	BLD T20/S7	SW6-T-SH	
LCD 220-239-8D	TS 40198D28	BLD T20/S7	SW6-T-SH	
LCD 240-259-8D	TS 40210D3	BLD T20/S7	SW6-T-SH	
LCD 260-279-8D	TS 50230D3	BLD T20/S7	SW6-T-SH	
LCD 280-299-8D	TS 50250D35	BLD T25/S7	SW6-T-SH	
LCD 300-319-8D	TS 60265D4	BLD T25/S7	SW6-T-SH	
LCD 320-349-8D	TS 60285D42	BLD T25/S7	SW6-T-SH	
LCD 350-379-8D	TS 60320D5	BLD T25/S7	SW6-T-SH	
LCD 380-410-8D	TS 80340D6	BLD T25/S7	SW6-T-SH	